

Model 1532R

SCISSOR LIFTS



MORE ECONOMIC

- Lower Total Cost of Ownership

MORE PRODUCTIVE

- Boost efficiency with optional AGM batteries
- Improved uptime

MORE ACCESS

- Get into more places with compact dimensions and precise positioning ability for both drive and lift

SMART DESIGN

- Improved reliable, simple active pothole protection
- Unparalleled component access
- All steel components like platform and service trays



Standard Features

- Proportional Controls
- Battery Condition Indicator
- 220V-AC Receptacle in Platform
- All Motion Alarm
- 27 amp Multi-Function Universal Charger
- Horn
- Hourmeter
- Tilt Alarm and Light
- Lanyard Attach Points
- Movable, Removable Platform Control
- Nickel Plated Pins
- Lubrication Free Scissor Arm Bushings
- Scissor Maintenance Prop
- Active Pothole Protection System
- Lifting and Tie Down Points
- Fork Lift Pockets
- 0.86 m Foot-Actuated Deck Extension
- Steel Swing-Out Doors
- Variable Tilt Window
- Manual Descent Cable
- Diamond Tread Steel Deck
- Greaseless Kingpin Joints
- Analyzer Port for Diagnostics
- Removable Ladder
- Self-Closing Gate

Standard Specifications

- Batteries
- Charger
- Drive
- Hydraulic Reservoir Capacity
- Hydraulic Reservoir Pump
- Tire Size/Type (Non-Marking)
- Brakes
- Pump Motor
- 4 x 6V 220 amp-hr
- 27 amp High Frequency Charger
- Hydraulic Front-wheel
- 18 L
- Fixed Displacement Gear
- 323 x 100 mm
- Multi-Disc Friction
- 4.5kW



Accessories & Options

- Flashing Amber Beacon
- 220 Amp-Hour AGM Batteries
- MDI (Ground)
- Anti-Vandalism Package for Ground Controls and Platform Controls
- Ambient Noise Alarm

Model 1532R

SCISSOR LIFTS

Performance

• Working Height	6.57 m
A. Stowed height	2.07 m
B. Platform Height - Lowered	0.95 m
C. Platform Railing Height	1.12 m
D. Stowed Height (Rails Folded)	1.61 m
E. Platform Size Inside (W x L)	0.55 m x 1.59 m
F. Deck Extension	0.86 m
G. Overall Width	0.81 m
H. Overall Length ²	1.74 m
I. Wheelbase	1.35 m
J. Ground Clearance (centre of machine)	7 cm
• Platform Capacity - Indoor	 /275 kg
• Platform Capacity - Outdoor	 /120 kg
• Lift/Lower Time (no load)	16 / 18 sec.
• Maximum Drive Height	4.57 m
• Machine weight ¹	1,357 kg
• Maximum Ground Bearing Pressure	8.09 kg/cm ²
• Drive Speed - Lowered	3.22 km/h
• Drive Speed - Elevated	0.80 km/h
• Gradeability	25%
• Turning Radius - Inside	0.0 m
• Turning Radius - Outside	1.69 m
• Tyres (Non-Marking Solid)	323 x 100
• Brakes	Hydraulic
• Drive (Nominal)	Hydraulic



1 Certain options or country standards may increase weight and/or dimensions.
2 Includes ladder, excluding ladder 1,67 m

Dimensions

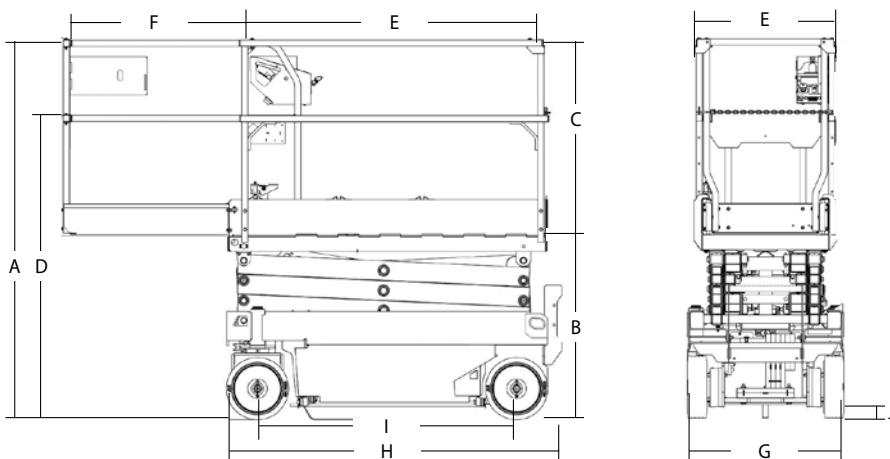

IMPORTANT

JLG is continually researching and developing products and reserves the right to make modifications without prior notice. All data in this document is indicative. Certain options or country standards will increase weight. Specifications may change to meet country standards or with the addition of optional equipment.

Due to continuous product improvements, JLG Industries reserves the right to make specification and/or equipment changes without prior notification.



JLG EMEA BV

Polaris Avenue 63
2132 JH Hoofddorp
The Netherlands
Tel: +31 (0)23 565 5665
www.jlg.com

An Oshkosh Corporation Company