



Cat[®] CS78B

Smooth Drum Vibratory Soil Compactor

The Cat[®] CS78B features a smooth drum and is ideally suited for granular soil applications or cohesive soil applications with the use of an optional padfoot shell kit.

Comfortable and Ergonomic Operator Station

- Features pivoting seat with integrated multifunction LCD display and control console.
- Outstanding visibility to the front and rear of machine.
- Low sound levels and vibration for greater operator comfort and productivity.

Rear Vision Camera

- The rear vision camera enhances visibility for more complete operator control and safety.

Exceptional Propel System

- Built around the exclusive Cat[®] dual pump propel system, two pumps provide separate dedicated flow to drum drive motor and rear axle motor for exceptional gradeability and traction in forward and reverse.
- Electronic propel control provides more precise machine control.

Virtually Maintenance Free

- Maintenance-free hitch bearings.
- Extended maintenance intervals for vibratory system and hydraulic system, providing more uptime and lower maintenance costs.

Enhanced Compaction Performance

- More weight at the drum and greater amplitude.
- Automated speed control and vibratory system functions make it easy to ensure consistent, high quality compaction.

Technologies that Enhance Quality and Productivity

- Exclusive semi-autonomous Command for Compaction technology automates compaction to offer complete process control to specification for greater productivity and uniform compaction quality.
- Measurement and documentation technologies help the operator determine when compaction has been completed to specification for greater productivity and uniform compaction quality.
- Accelerometer-based (CMV) and exclusive Machine Drive Power (MDP) measurement technology available.



Cat® CS78B Smooth Drum Vibratory Soil Compactor

Standard and Optional Equipment

Standard and optional equipment may vary. Consult your Cat dealer for details.

	Standard	Optional		Standard	Optional
OPERATOR ENVIRONMENT			POWER TRAIN		
ROPS/FOPS Cab with Climate Control, External Rear View Mirrors	✓		Cat C4.4 Diesel Engine	✓	
Cloth Adjustable Pivoting Seat with Integrated Console and LCD Display	✓		Air Cleaner, Dual Element	✓	
Adjustable Tilting Steering Column with Integrated Cup Holders	✓		Three-Speed Throttle Switch, Eco-mode and Automatic Speed Control	✓	
Rear Vision Camera with Color Touchscreen Display	✓		Dual Propel Pumps; One for Drum Drive, One for Rear Axle	✓	
High Visibility Orange 50 mm (2 in) Seat Belt	✓		Fuel Filter, Water Separator, Priming Pump, Water Indicator	✓	
12-volt Power Outlet	✓		Tilting Radiator/Hydraulic Oil Cooler	✓	
Horn, Backup Alarm	✓		Dual Braking System	✓	
Internal Rear View Mirror		✓	Two-speed Hydrostatic Transmission	✓	
Sun Visor		✓	Transmission Guard		✓
Cab Internal Roll-down Sun Screen		✓	ELECTRICAL		
High Visibility Orange 76 mm (3 in) Seat Belt		✓	24 volt Electrical System	✓	
VIBRATORY SYSTEM			100 ampere Alternator	✓	
Smooth Drum	✓		750 Cold-cranking Amps Battery Capacity	✓	
Dual Amplitude, Single Frequency	✓		OTHER		
Dual Pod-Style Eccentric Weight Housings	✓		Product Link™	✓	
Auto-vibe Function	✓		Sight Gauges Hydraulic Oil Level and Radiator Coolant Level	✓	
Front Adjustable Steel Scraper	✓		S•O•S SM Sampling Valves: Engine Oil, Hydraulic Oil and Coolant	✓	
Padfoot Shell Kit (oval or square pads available)		✓	Machine tie downs - front and rear (meet ISO 15818)	✓	
Variable Frequency		✓	Recording Module		✓
Dual Adjustable Steel Scrapers		✓	Factory Filled Bio Hydraulic Oil		✓
Dual Adjustable Polyurethane Scrapers		✓	Upgraded Halogen Light Package		✓
TECHNOLOGY SOLUTIONS			Upgraded LED Light Package		✓
Measure - Machine Drive Power		✓	Amber Rotating Beacon		✓
Map - SBAS GNSS Mapping		✓	Fuel Fill Access Door		✓
Connect - Cloud and Machine Connectivity		✓			
Command for Compaction		✓			

Cat® CS78B Smooth Drum Vibratory Soil Compactor

Vibratory Soil Compactor Selection Guide

16 - 20 T

Assumes density specification is 95% of Standard Proctor and can vary substantially due to different soil conditions.

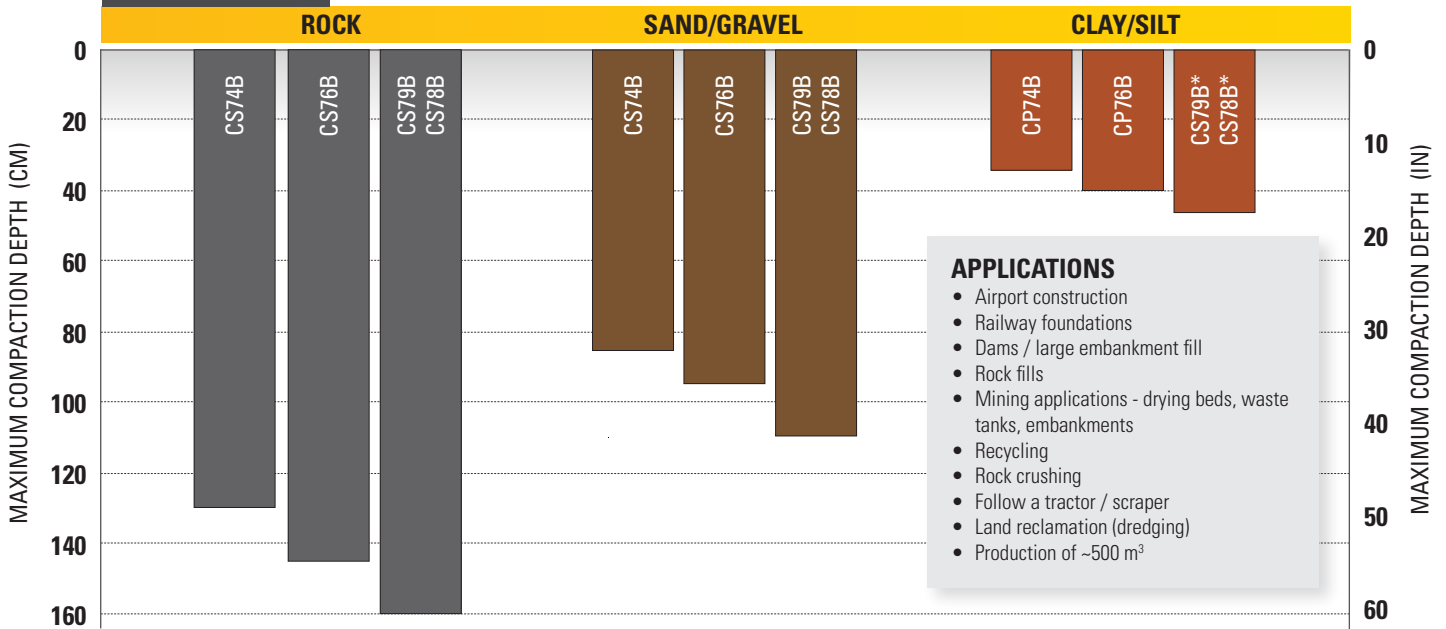

APPLICATIONS

- Airport construction
- Railway foundations
- Dams / large embankment fill
- Rock fills
- Mining applications - drying beds, waste tanks, embankments
- Recycling
- Rock crushing
- Follow a tractor / scraper
- Land reclamation (dredging)
- Production of ~500 m³

Rock

Smooth drum, high amplitude moving to low amplitude when approaching compaction, 4-8 passes

Size: Less than 50 mm (2 in) diameter

Sand/Gravel

Smooth drum, high amplitude moving to low amplitude when approaching compaction, 4-6 passes

Clay/Silt

Padfoot and smooth drum application (for smoothing), 4-10 passes. Compaction in cohesive soils strongly depends on moisture content.

* Smooth drum model equipped with padfoot shell kit

Cat® CS78B Smooth Drum Vibratory Soil Compactor

Technical Specifications

Engine - Power Train		
Engine Model	Cat® C4.4	
Emissions	EU Stage V	
Engine Power ISO 14396:2002	129.4 kW	173.5 hp
Gross Power SAE J1995:2014	130.4 kW	174.9 hp
Net Power ISO 9249:2007*	108.7 kW	145.8 hp
Net Power SAE J1349:2011*	108.2 kW	145.1 hp
Displacement	4.4 L	268.5 in ³
Stroke	127 mm	5 in
Bore	105 mm	4.1 in
Max. Travel Speed (Forward or Reverse)	11.4 km/h	7 mph
Theoretical Gradeability, no vibration**	53%	

Vibratory System Specifications		
Frequency		
Standard	28 Hz	1680 vpm
During Eco-mode Operation	25.5 Hz	1527 vpm
Optional Variable Frequency	23.3-28 Hz	1400-1680 vpm
Nominal Amplitude @ 30.5 Hz (1830 vpm)		
High	2.1 mm	0.083 in
Low	0.98 mm	0.039 in
Centrifugal Force @ 30.5 Hz (1830 vpm)		
Maximum	335 kN	75,234 lb
Minimum	156 kN	35,153 lb
Static Linear Load		
w/ ROPS/FOPS cab	63.0 kg/cm	352.8 lbs/in
VM Class at High Amplitude	VM5	

Weights		
Operating Weight w/ ROPS/FOPS cab***	18 888 kg	41,641 lb
w/ Oval Padfoot Shell Kit	19 178 kg	42,280 lb
w/ Square Padfoot Shell Kit	19 337 kg	42,631 lb
Weight at Drum w/ ROPS/FOPS cab	13 443 kg	29,637 lb
w/ Oval Padfoot Shell Kit	13 127 kg	28,940 lb
w/ Square Padfoot Shell Kit	13 286 kg	29,291 lb

Service Refill Capacities		
Fuel Tank, total capacity	332 L	88 gal
Diesel Exhaust Fuel refill capacity	19 L	5 gal
Cooling System	28.2 L	7.5 gal
Engine Oil w/ Filter	11.6 L	3.1 gal
Eccentric Weight Housings (combined)	26 L	6.9 gal
Axle and Final Drives	18 L	4.8 gal
Hydraulic Tank (service refill)	50 L	13.2 gal

* Net power advertised is the power available at the engine flywheel when equipped with a fan at maximum speed, air cleaner, clean emissions module, and alternator.

** Actual gradeability may vary based on site conditions and machine configuration. Refer to the Operation and Maintenance Manual for more information.

*** Standard operating weight considers full fuel tank, 75 kg operator, traction tires, oval pad drum, and cab with A/C.

Cat® CS78B Smooth Drum Vibratory Soil Compactor

Technical Specifications

Dimensions			
1	Overall Length	6.1 m	19.9 ft
2	Overall Width	2.5 m	8.1 ft
3	Drum Width	2134 mm	84 in
4	Drum Shell Thickness	40 mm	1.6 in
5	Drum Diameter	1535 mm	60.4 in
6	Overall Height	3.1 m	10.2 ft
7	Wheelbase	2.9 m	9.5 ft
8	Ground Clearance	434 mm	17.1 in
9	Curb Clearance	533 mm	21.0 in
	Inside Turning Radius	3.7 m	12.1 ft
	Hitch Articulation Angle	34°	
	Hitch Oscillation Angle	15°	

Padfoot Specifications			
Number of Pads		120	
Pad Height, oval pads		89.8 mm	3.5 in
Pad Face Area, oval pads		63.5 cm ²	9.8 in ²
Pad Height, optional square pads		89.8 mm	3.5 in
Pad Face Area, optional square pads		105.7 cm ²	16.4 in ²
Number of Chevrons		16	

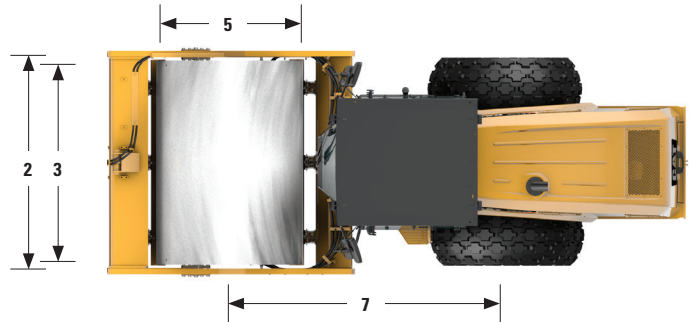
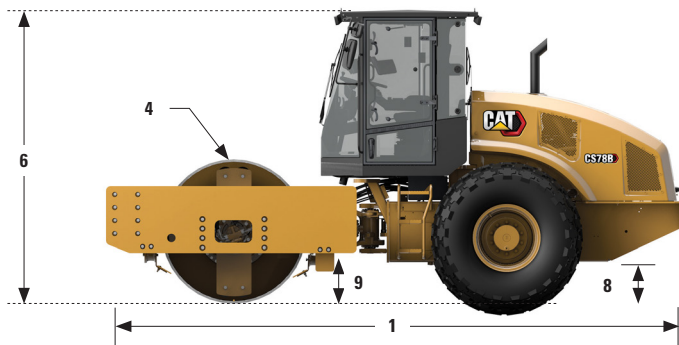

Cat® CS78B Smooth Drum Vibratory Soil Compactor

Environmental Declaration

The following information applies to the machine at the time of final manufacture as configured for sale in the regions covered in this document. The content of this declaration is valid as of the date issued; however, content related to machine features and specifications are subject to change without notice. For additional information, please see the machine's Operation and Maintenance Manual.

For more information on sustainability in action and our progress, please visit www.caterpillar.com/en/company/sustainability.html.

ENGINE

- The Cat C4.4 is available in configurations that meet Stage V emissions standards.
- Cat diesel engines are required to use ULSD (ultra-low sulfur diesel fuel with 15 ppm of sulfur or less) or ULSD blended with the following lower-carbon intensity fuels up to:
 - ✓ 20% biodiesel FAME (fatty acid methyl ester)
 - ✓ 100% renewable diesel, HVO (hydrogenated vegetable oil) and GTL (gas-to-liquid) fuels

Refer to guidelines for successful application. Please consult your Cat dealer or "Caterpillar Machine Fluids Recommendations" (SEBU6250) for details.

AIR CONDITIONING SYSTEM

The air conditioning system on this machine contains the fluorinated greenhouse gas refrigerant R134a (Global Warming Potential = 1430). The system contains 0.8 kg (1.8 lb) of refrigerant, which has a CO₂ equivalent of 1.144 metric tonnes (1.261 tons).

PAINT

- Based on best available knowledge, the maximum allowable concentration, measured in parts per million (PPM), of the following heavy metals in paint are:
 - Barium < 0.01%
 - Cadmium < 0.01%
 - Chromium < 0.01%
 - Lead < 0.01%

SOUND PERFORMANCE

With cooling fan speed at maximum value:

Exterior Sound Power Level (ISO 6395:2008) – 109 dB(A)

With cooling fan speed at 70% of maximum value:

Operator Sound Pressure Level (ISO 6396:2008) – 79 dB(A)

- When properly installed and maintained, the cab offered by Caterpillar, when tested with doors and windows closed according to ANSI/SAE J1166 OCT98, meets OSHA and MSHA requirements for operator sound exposure limits in effect at time of manufacture.
- Hearing protection may be needed when operating with an open operator station and cab (when not properly maintained or doors/windows open) for extended periods or in a noisy environment.

OILS AND FLUIDS

- Caterpillar factory fills with ethylene glycol coolants. Cat Diesel Engine Antifreeze/Coolant (DEAC) and Cat Extended Life Coolant (ELC) can be recycled. Consult your Cat dealer for more information.
- Cat BIO HYDO™ Advanced is an EU Ecolabel approved biodegradable hydraulic oil.
- Additional fluids are likely to be present, please consult the Operations and Maintenance Manual or the Application and Installation guide for complete fluid recommendations and maintenance intervals.

FEATURES AND TECHNOLOGY

- The following features and technology may contribute to fuel savings and/or carbon reduction. Features may vary. Consult your Cat dealer for details.
 - Standard mode limits engine RPM, lowering overall fuel consumption compared to high idle
 - Optional compaction control reduces unnecessary passes, contributing to lower overall fuel consumption
 - Extended maintenance intervals reduce fluid and filter consumption
 - Auto idle shutdown reduces unproductive hours and fuel burned
 - Hydraulic on-demand fan changes speed with temperature

Cat® CS78B Smooth Drum Vibratory Soil Compactor

Cat® CS78B Smooth Drum Vibratory Soil Compactor

For more information on Cat products, dealer services, and industry solutions visit us on the web at www.cat.com.

© 2022 Caterpillar
All rights reserved.

Materials and specifications are subject to change without notice. Featured machines in photos may include additional equipment. See your Cat dealer for available options.

CAT, CATERPILLAR, LET'S DO THE WORK, their respective logos, "Caterpillar Corporate Yellow," the "Power Edge" and Cat "Modern Hex" trade dress as well as corporate and product identity used herein, are trademarks of Caterpillar and may not be used without permission.

QEHQ2876-01 (07-2022)
Europe

